

Goods Handling Specifications

In order to maintain a consistently high standard of service to our clients we ask that every effort is made to adhere to our **Goods Handling Specifications**; paying particular attention to our **Goods In Procedure** and **Pallet Specifications** as itemised below.

Goods In Procedure

We request that transport companies deal directly with our stock control department in the distribution centre. All deliveries to be booked in prior to delivery by one of the following procedures:

1. Complete attached delivery note to include the following:
 - Requested delivery date and time
 - Haulier Name, Address, Contact name and telephone
 - Client Name, Address, Contact name and telephone
 - CJ's Project ID
 - Product codes for items being delivered
 - Weight of items
 - Quantities of items
 - Total number of boxes/cartons
 - Total number of pallets



K:\Warehouse\
Warehouse forms\De

2. Book in using one of the following options:
 1. via stock control – **T 01928 531 742**
 - Date and time agreed and Booking in Reference will be issued
 2. via email warehouseadminteam@cjservices.co.uk
 - Date and time – every effort will be made to accommodate your requested unloading times
 - Date, time and Booking in Reference will be returned via email

Please Note: Where possible we will also deal with unscheduled deliveries.

- Any deliveries which have not been pre booked will be dealt with after all of our scheduled deliveries, and may be turned away.
- Any deliveries arriving at our distribution centre without the above delivery paperwork may experience longer unloading times while the required delivery information is obtained and processed.

Identification – label requirements

One label should be positioned on the top face or side or the outer package, as stacked on the pallet.

Printed materials must be clearly labelled as per the attached label layout.

Pallets

Complete and attach a pallet label for all pallets being delivered.

- Client Name / Project ID
- Booking in Reference
- Pallet Number – (all pallets need to be numbered sequentially)
- Total Number of Pallets in this delivery
- Description of Stock Items
- Quantity of Stock Items (in each box/carton)
- Quantity of boxes/cartons (contained on pallet per stock item)



K:\Warehouse\
Warehouse forms\Pal

Boxes/cartons

Any individual boxes/cartons (courier deliveries) should also be labelled with the following:

- Client name/ Project ID
- Booking in Reference – if applicable
- Number of boxes in delivery
- Description of stock items
- Quantity of stock items (in each box/carton)

Pallet Specifications

In order to ensure efficient unloading of your delivery, please adhere to the following standards:

- Dimensions
- Wrapping
- Stacking
- Boxes/cartons
- Identification (labels)

Please note:

1. Ideally pallets should not contain mixed items of stock
2. Pallets should be of sturdy construction and suitable for purpose

Dimension requirements

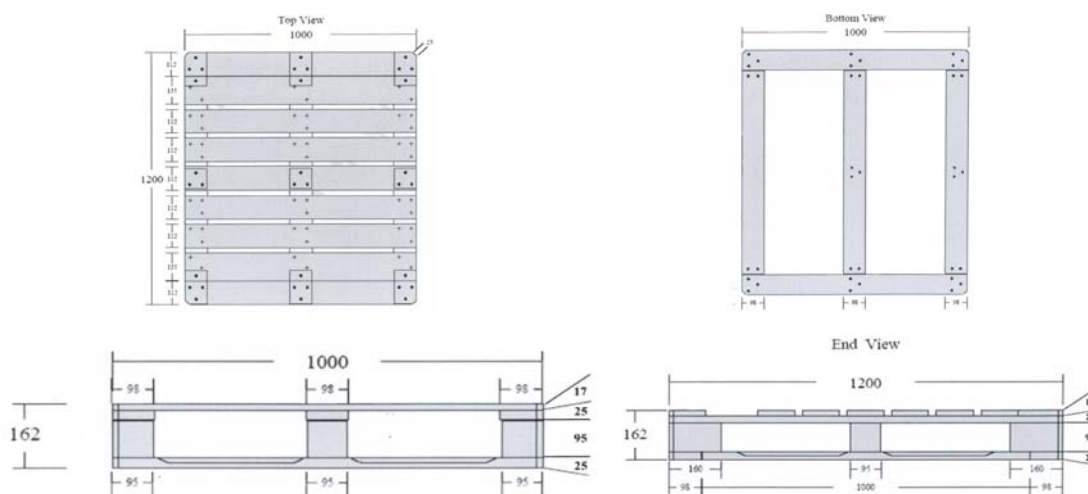

Pallet Type: Standard non-returnable 1200mm x 1000mm (48" x 40")
Pallet Weight: Maximum gross weight 500kg
Pallet Height: Maximum total height 1500mm

Wrapping requirements

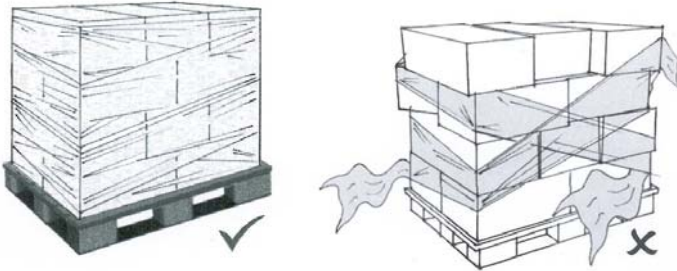

Pallets should have a flat top and be film wrapped or strapped to facilitate two-high stacking and protection against movement during transit.

Stacking requirements

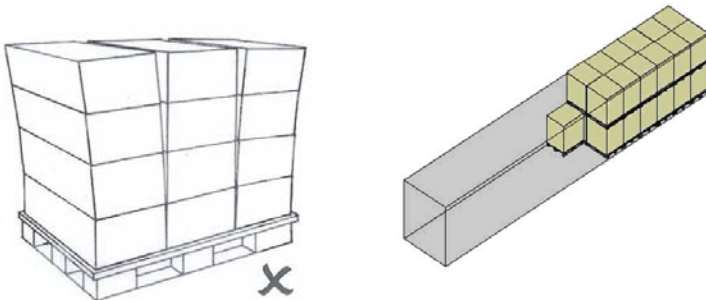

The structure of the load should allow the strapping/wrap to be opened and items taken off without the load falling.

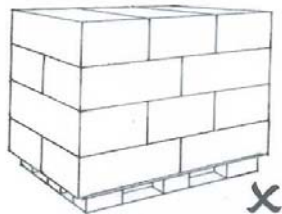

Stock should not overlap the base of the pallet making the overall dimension greater than that specified above.

Boxes/carton requirements

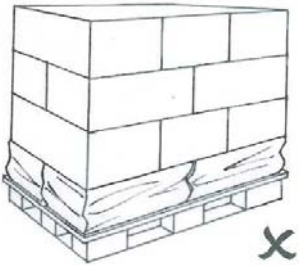

Please ensure all boxes/cartons:

- Are suitable for the purpose, and not prone to splitting or collapsing
- A suitable size for the contents so that they can be stacked safely
- Filled with suitable packing material to ensure they do not collapse if partially full
- Contain consistent definable quantities - e.g. number of items per boxes/carton, and be clearly labelled with the relevant details
- Over 20kg are marked as heavy with the weight printed on the box



Please note:

- It is essential that these requirements are adhered to, or additional charges may be incurred for receiving and unloading stock which is not palletised as per below.
- Any prices quoted for receipt of stock assume that the stock will be received on suitable pallets, and that those pallets can be removed from the delivering vehicle by forklift truck.
- In order to meet Health & Safety regulations we reserve the right to re-palletise any stock received on unsuitable or broken pallets, and to pass the cost to our client.